

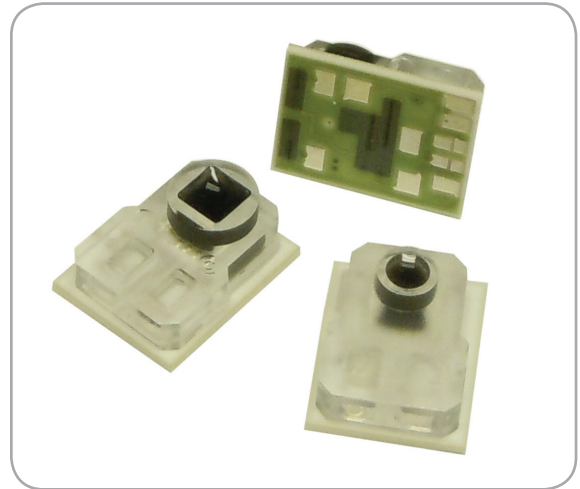

NPC-100 and NPC-120 Series

NovaSensor
Disposable Medical
Pressure Sensors



Features

- Solid state, high reliability
- Media compatibility
- High performance
- Factory filled with dielectric gel
- Small size
- Fully tested
- Temperature compensated
- Low cost disposable design
- Designed to AAMI specifications

Applications

- Medical instrumentation
- Blood pressure measurement
- Infusion pumps
- Kidney dialysis machines

Amphenol
Advanced Sensors

NPC-100 and NPC-120 Series Specifications

The NovaSensor NPC-100 and NPC-120 Series pressure sensor are specifically designed for use in disposable medical applications. The devices are compensated and calibrated per the Association for the Advancement of Medical Instrumentation (AAMI) guidelines for industry acceptability. The sensors integrate a high-performance, pressure sensor die with temperature compensation circuitry and gel protection in a small, low-cost package.

The NPC-100 and NPC-120 Series are manufactured in a class 1000 clean-room to minimize possible sources of contamination. A specially designed silicon micromachined sensing element is used to meet or exceed all industry requirements while minimizing assembly and test cost for maximum customer value. Thick-film laser-trimming is employed for final compensation and calibration. Sensitivity is maintained to $\pm 1\%$ and linearity is better than 1% in the physiological operating pressure range.

The NPC-100 and NPC-120 Series are batch-manufactured in ceramic plate form and shipped as an intact array or in Tape and Reel for easy customer automation. This assembly method draws from well-established manufacturing techniques used in the electronics industry in order to produce a quality, high volume product.

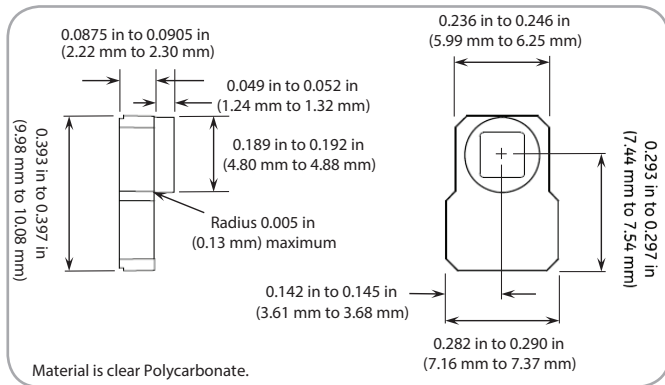

NPC-100 Series pressure sensor port interface

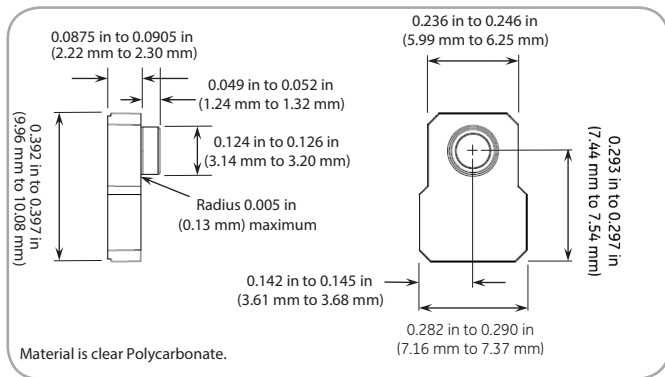

NPC-120 Series pressure sensor port interface

Parameter	Value	Units	Notes
General			
Pressure Ranges	-50 to 300	mmHg	-0.97 psi to 5.8 psi
Overpressure	125	psi	minimum
Electrical @ 72°F (22°C) Unless Otherwise Stated			
Input Excitation	1 to 10	VDC	Calibrated for 6 VDC
Dielectric Breakdown	10,000	VDC	5
Risk Current	2	μA	Maximum (per AAMI), 5
Input Impedance	1800 to 3300	Ω	
Output Impedance	285 to 315	Ω	
Environmental			
Temperature			
Compensated	15°C to 40°C	°C	(59° to 104°F)
Operating	15°C to 40°C	°C	(59° to 104°F)
Storage	-25°C to 70°C	°C	(-13° to 158°F)
Humidity	10 to 90	%	
Light Sensitivity	1	mmHg	maximum (per AAMI BP22)
Operating Product Life	168	hours	
Shelf Life	5	years	
Mechanical			
Weight	<0.0044	lb	(<2 g)
Media Interface	Medical grade, dielectric gel		
Gel Tube Interface Material	Polycarbonate		

Parameter	Units	Minimum	Type	Maximum	Notes
Performance Parameters*					
Offset	mmHg	-20	0	20	
Sensitivity	$\mu\text{V/V/mmHg}$	4.95	5	5.05	
Calibration	mmHg	97.5	100	102.5	2
Symmetry	%	-	-	± 5	
Linearity (-30 to 100 mmHg)	mmHg	-	-	1	6
Linearity (100 to 200 mmHg)	% output	-	-	1	6
Linearity (200 to 300 mmHg)	% output	-	-	1.5	6
Thermal Coefficient Offset	mmHg/°C	-	-	± 0.3	3
Thermal Coefficient Span	%/°C	-	-	± 0.1	3
Frequency Response	Hz	1200	-	-	5
Phase Shift	degrees	-	-	5	5
Offset Drift	mmHg/8 hrs	-	-	1	4,5

1. All values measured at 6 VDC and 71.6°F (22°C) and after five second warm up unless otherwise specified.
2. Output of sensor with no pressure applied and a 150 k Ω resistor shorted across +IN to +OUT.
3. Over a temperature range of 59°F to 104°F (15°C to 40°C).
4. Normalized offset/bridge voltage—8 hours after 20 seconds, warm-up.
5. Previously qualified, not tested in production.
6. Deviation from straight line drawn through zero and 100 mmHg data points.
7. These sensors are compatible with ETO (ethylene oxide) sterilization. The user is responsible for establishing and validating suitable process conditions to prevent damage to the sensor.

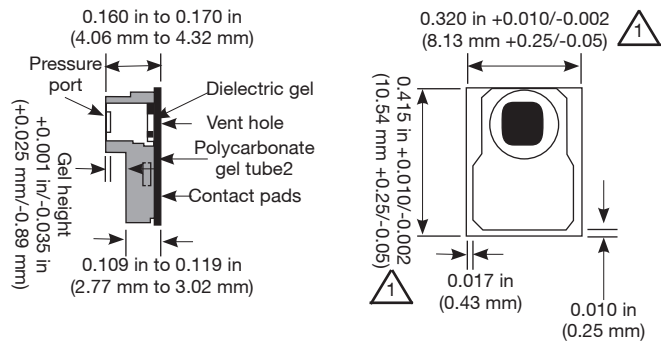

1. Tolerances reflect typical flaring during the singulation process.

NPC-100 Series package diagram

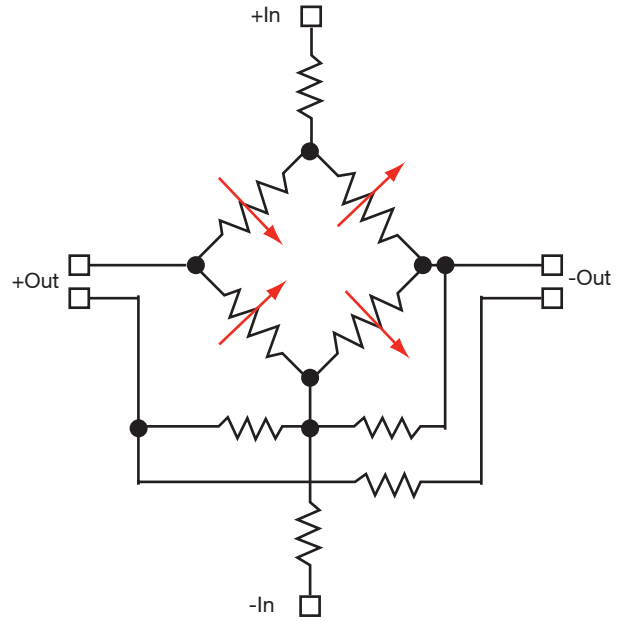
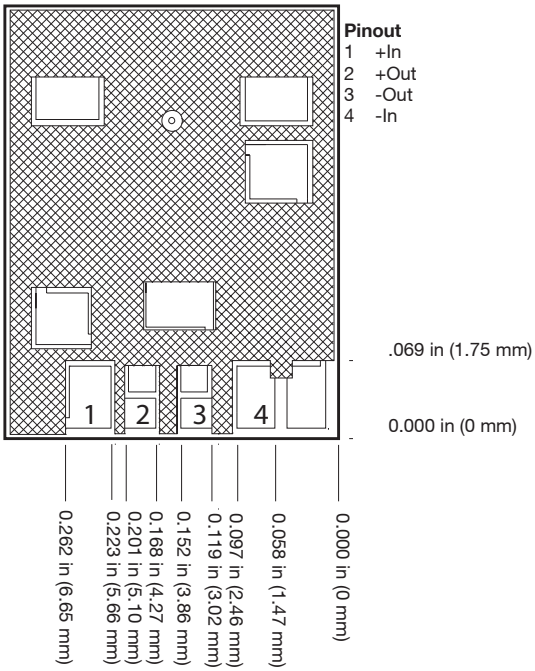

NPC-100 Series schematic diagram

1. Tolerance on electrical pad location is ± 0.010 in (± 0.25 mm).
2. Contact pads are suitable for soldering.
3. Split pads on +Out and -Out must be connected for proper operation.
4. All dimensions assume a nominal 0.01 in (0.25 mm) distance between the edge of the solder pads to the edge of the ceramic. This distance will vary slightly from part to part.

NPC-100 Series electrical interface

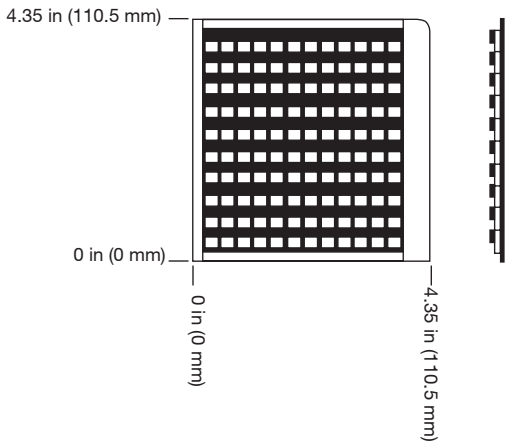

1. Sensors are shipped as 120 UP snapstrates that must be singulated by the customer.
2. Each reel or plate may include units that have failed visual or electrical parameters as well as good units. Bad units are identified with a dot on the backside of the cell location.
3. Reels and plates are shipped in dust free anti-static containers to prevent contamination of the gel surface.

NPC-100 Series shipping Configuration

Ordering Information

The code number to be ordered may be specified as follows:

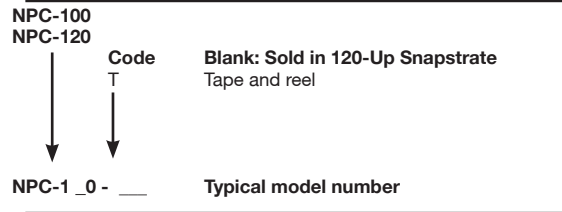

Amphenol

Advanced Sensors

www.amphenol-sensors.com

© 2016 Amphenol Corporation. All Rights Reserved. Specifications are subject to change without notice. Other company names and product names used in this document are the registered trademarks or trademarks of their respective owners.