



P162

NovaSensor 2.5F Medical Silicon Gage Pressure Sensor Die

NovaSensor's P162 piezoresistive pressure sensor die is offered in a miniature 1150 x 725 μm die that is small enough for three French catheters.

The small die size is made possible by NovaSensor's proprietary Silicon Fusion Bonding (SFB) process. When excited with an AC or DC voltage source, the P162 produces a mV output that is proportional to input pressure.

The P162 is in a halfbridge design, where external resistors are needed to complete a full bridge configuration.

Features

- Very small size
- Gage pressure sensing
- Standard pressure range -50 to 300 mmHg Gage
- AC or DC excitation
- 4000 mmHg burst limit
- Wafer location marked on every die for traceability
- Tight control of sensitivity

Applications

- IUP
- Intracranial
- Disposable Pressure Catheters
 - Intrauterine
 - Intracranial
 - Body

P162 Specifications

Performance Parameters ⁽¹⁾	Value ⁽⁶⁾	Units	Notes
Pressure Range	-50 to 300	mmHg	Gage
Operating Temperature	50 to 122	°F	(10°C to 50°C)
Excitation	1 to 8	Volts	AC or DC
Zero Offset	±12.5	mV/V	
Sensitivity	12 to 27	μV/V/mmHg	2
Linearity and Pressure Hysteresis	±2% of reading or ±1 mmHg whichever is larger	%FSO	3, 4
Temperature Coefficient of Zero	±40	μV/V/°C	7
Temperature Coefficient of Zero Non-Linearity	±1.25	mmHg	7
Temperature Coefficient of Resistance	0.1	%/°C	Typical
Temperature Coefficient of Sensitivity	-0.2	%FSO/°C	Typical
Bridge Resistance	800 ± 20%	Ω	
Symmetry	±5	%	5
Burst Pressure	4000	mmHg	Gage
Media Compatibility	Clean, dry, and non-corrosive gases		6

1. Values measured at 0.6 mA and 71.6°F (22 °C) unless noted with 800 Ω resistor between +Out and -IN, and -Out and -IN. Die performance will vary depending on die attach material. The die attach material should be chosen to minimize package stress transmitted to the sensor die.
2. Sensitivity at 100 mmHg.
3. Extrapolated error at 300 mmHg by straight line through 0 and 100 mmHg pressure readings
4. Topside pressure.
5. Percent of the bridge resistor with the lowest value. Symmetry is the difference between the two bridge resistor values.
6. A protective coating must cover the sensor die for use with saline and other fluids.
7. 15 °C to 40 °C.

Shipping And Handling

Wafers are shipped in protective plastic containers, and if needed, die can be shipped in gel paks. The wafers are sawn on sticky tape with plastic rings. All sensor wafers are electrically probed, visually inspected. All rejects are marked by an ink dot. Each wafer will be labeled with the lot number wafer number, device number and the number of available sensor die.

Ordering Information

Part Number	Description
51564	2.5F, 300 mmHg Gage

Amphenol

Advanced Sensors

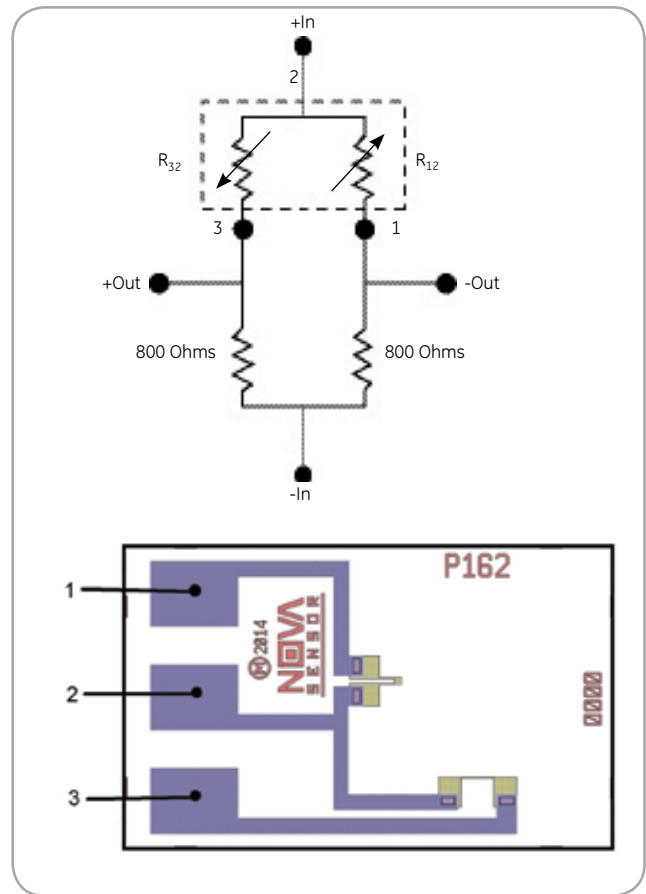

Die dimensions (l x w x h): 1150 μm x 725 μm x 170 μm
P162 schematic diagrams

Warranty

Amphenol Advanced Sensors warrants its products against defects in material and workmanship for 12 months from the date of shipment. Products not subjected to misuse will be repaired or replaced. NovaSensor reserves the right to make changes without further notice to any products herein.

Amphenol Advanced Sensors makes no warranty, representation or guarantee regarding the suitability of its products for any particular application, nor does Amphenol Advanced Sensors assume any liability arising out of the application or use of any product or circuit and specifically disclaims and all liability without limitation consequential or incidental damages. The foregoing warranties are exclusive and in lieu of all other warranties, whether written, oral, implied or statutory. No implied statutory warranty of merchantability or fitness for particular purpose shall apply.

www.amphenol-sensors.com

© 2015 Amphenol Corporation. All Rights Reserved. Specifications are subject to change without notice. Other company names and product names used in this document are the registered trademarks or trademarks of their respective owners.

AAS-920-641B-06/2015