



# P1300

## Low Pressure Silicon Pressure Sensor Die

The **NovaSensor P1300 Low Pressure Die** is a piezoresistive sensing element measuring 2.7mm x 3.2mm (0.11in x 0.13in). When excited with constant voltage or constant current, it produces a millivolt output proportional to input pressure. Manufactured with NovaSensor's SenStable® process, the P1300 die provides excellent long-term stability and repeatability. The die can be used for differential and gauge pressure sensors.

### Features

- High pressure sensitivity
- High stability
- High linearity
- Available Versions: Gauge
- Standard Pressure ranges: 1 psi (6.9 kPa)

### Applications

- Smart building & HVACR
- Home Safety & Security
- Personal Care & Health Devices
- Instrumentation
- Aerospace and Defense

# P1300 Low Pressure Sensor Die Specifications

Parameter		Value	Units	Notes		
<b>General</b>						
Pressure Range	Gage	1	psig	-		
Proof Pressure		10X rated pressure		2		
Backside Burst Pressure		35	psi	3		
<b>Environmental</b>						
Temperature Range	Operating	-40 to 150	°C	4		
	Storage	-55 to 150	°C	-		
<b>Mechanical</b>						
Die Dimensions (L x W x H)	With 93 mil glass	3.2 mm x 2.7 mm x 2.8 mm		-		
Wire Bond Pad Dimension		0.25 mm x 0.25mm				
Metallization		Pure aluminum				
Media Compatibility		Clean dry air, media compatible with silicon and boron-silicate glass				
<b>Electrical Performance (1)</b>						
Parameter		Min	Typical	Max	Units	Notes
Recommended Excitation	Current	-	1.5	1.6	mA	-
	Voltage	-	5	8	V	-
Input and Output Impedance		4000	5300	6000	Ohm	-
Zero Offset	Other	-10	within $\pm 5$	+10	mV/V	5
Full Scale Output (FSO or Span)		75	90	130	mV	-
Sensitivity		1.3	1.6	2.6	mV/V/KPa	-
Linearity (Best Fit Straight Line)		-0.2	within $\pm 0.1$	+0.2	-	4
Zero Pressure Repeatability		-0.2	within $\pm 0.1$	+0.2	%FSO	4
Temperature Coefficients	Zero (TCO)	-15	within $\pm 10$	15	$\mu\text{V/V}/^\circ\text{C}$	4, 6
	Resistance (TCR)	0.32	0.36	0.45	$\%/^\circ\text{C}$	4
	Sensitivity (TCS)	-0.29	-0.23	-0.18	$\%/^\circ\text{C}$	4
Zero Thermal Hysteresis		-0.25	within $\pm 0.1$	+0.25	%FSO	4, 6
FSO Thermal Hysteresis		-0.25	within $\pm 0.1$	+0.25	%FSO	4, 6

## Notes:

- All values measured at 25 °C and 1.5 mA excitation, unless otherwise noted.
- Proof pressure is the maximum pressure die occasionally can be exposed to without causing permanent damage or performance change. Die performance cannot be guaranteed after exposure to pressure that exceeds the proof pressure.
- Burst pressure is a pressure causing permanent structural damage of die. Front side burst pressure is higher than back side burst pressure. Die products can be qualified for a higher burst pressure with additional testing in customer package.
- Samples from each wafer are used to verify bridge resistance, offset, span, linearity and temperature characteristics in the temperature range between 0°C and 70°C.
- Measured at 0 kPa pressure.
- Die packaging may have a large impact on sensor stability, pressure hysteresis, thermal hysteresis, and TCO.

# P1300 Low Pressure Sensor Die Specifications

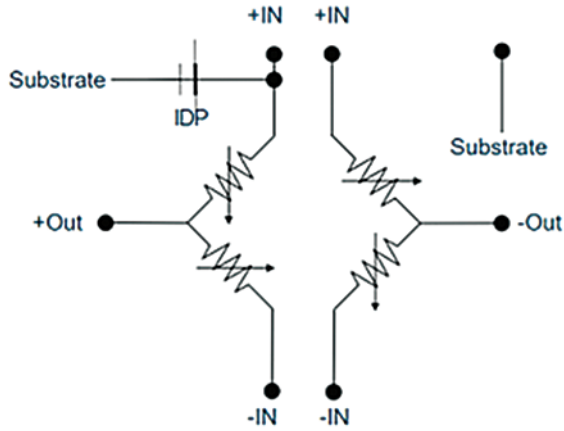

P1300 Schematic Diagram

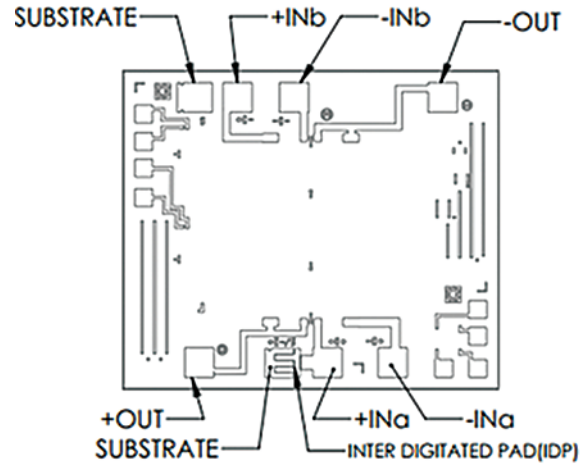

P1300 Wire Bond Diagram

Note: Both +IN and SUBSTRATE need to be connected to the highest potential in the circuitry

## P1300 Ordering Information:

93 mil (2.36 mm) Thick Glass			
PN	Range		Gage/ Absolute
	PSI	kPa	
71367	1	6.9	G

- All products are supplied either as sawn 6" wafers on tape or as die in Gel-Paks.
- Minimum release quantity: 1200 (sawn wafer on tape), 100 (die in Gel-Pak).

The product part number to be ordered may be specified as follows:

### Part number

71367	Sawn wafer on tape
71367-GP	Die in Gel-Pak

## Shipping and Handling

The standard products are available on tape with metal frame after dicing and are shipped in protective plastic containers. Electrical rejects and visual rejects are inked. Each wafer will have the following information: Lot #, Wafer #, Part #, and the number of good (yielded) die.

## Warranty

NovaSensor warrants its products against defects in material and workmanship for 12 months from date of shipment. Products not subject to misuse will be repaired or replaced. THE FOREGOING IS IN LIEU OF ANY OTHER EXPRESSED OR IMPLIED WARRANTIES. NovaSensor reserves the right to make changes without further notice to any products herein. NovaSensor makes no warranty, representation or guarantee regarding the suitability of its products for any particular application, nor does NovaSensor assume any liability arising out of the application or use of any product or circuit, and specifically disclaims and all liability, including without limitation consequential or incidental damages.

# Amphenol Sensors

[www.amphenol-sensors.com](http://www.amphenol-sensors.com)

© 2026 Amphenol Corporation. All Rights Reserved. Specifications are subject to change without notice.  
Other company names and product names used in this document are the registered trademarks or  
trademarks of their respective owners.

AAS-920-440C - 05/2026